

1. REMOVE ALL BURRS AND SHARP EDGES
2. A RADIUS OR CHAMFER OF 0.2mm (MAX) IS PERMITTED IN THE CORNERS, HOLES & RECESSES

3. SURFACE FINISH N7 UNLESS OTHERWISE STATED
4. ALL DIMENSIONS ARE AFTER SPECIFIED FINISH

DRAWN TO BS 8888
DO NOT SCALE

THIS DRAWING IS THE PROPERTY OF CHSS ENGINEERING SYSTEMS LIMITED AND SHALL NOT, IN PART OR IN WHOLE, WITHOUT OUR WRITTEN PERMISSION, BE COPIED, REPRODUCED IN ANY WAY, USED FOR MANUFACTURING, OR COMMUNICATED TO ANY OTHER PERSON OR COMPANY

IF IN DOUBT ASK

UNCONTROLLED WHEN PRINTED

ALTERATIONS

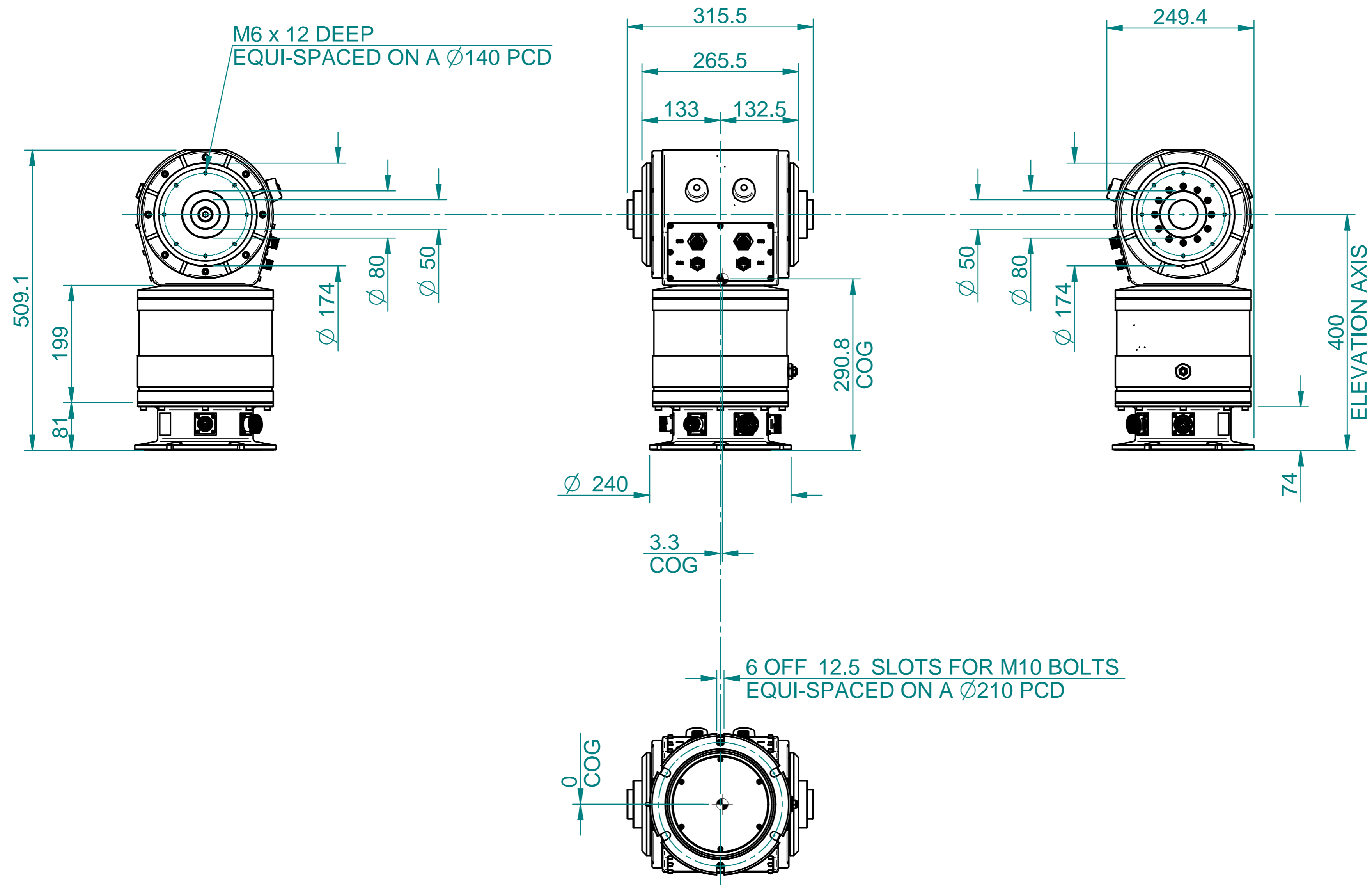

MASS : 37Kg

Unit 7, North Heath Industrial Estate, North Heath Lane, Horsham,
West Sussex, United Kingdom, RH12 5QE
email: info@chess-sys.com http://www.chess-dynamics.com
Tel: (+44)01403 249888 Fax: (+44)01403 249555



MATERIAL

SURFACE FINISH

SCALE 1:5 @ A2

GENERAL TOLERANCES
LINEAR 2 DEC. PLACES ± 0.1
ALL OTHER DIMENSIONS ± 0.25
ANGULAR $\pm 0.5^\circ$

DRAWN RJF

DATE 01/09/2010

DESIGN

TITLE

Zeta Electro Optical Director

PROJECT

RELEASED

DRAWING No.

ED014-01-0100-00

Outline Drawing

ISSUE

1A

A2