

CHARM-100NX

Video Processing Board 100mm x 100mm x 27mm

The Vision4ce CHARM-100NX is a standalone video processing board for embedded video and image processing applications, which is designed to host the Vision4ce FrameWorkx image processing software which includes the field proven DART video tracking software. The CHARM-100NX is based on a NVIDIA Xavier NX embedded processor which incorporates a multicore ARM processor and powerful GPU.

The standard video interfaces are 3G SDI. Optional video interfaces are supported through a video mezzanine which can include PAL, NTSC, YUV, CameraLink and CoaxPress. The primary host interface is through an Ethernet port. Multiple serial links are also provided. The M.2 slot can be used to add up to an SSD, 2 additional Ethernet ports, or other connections.

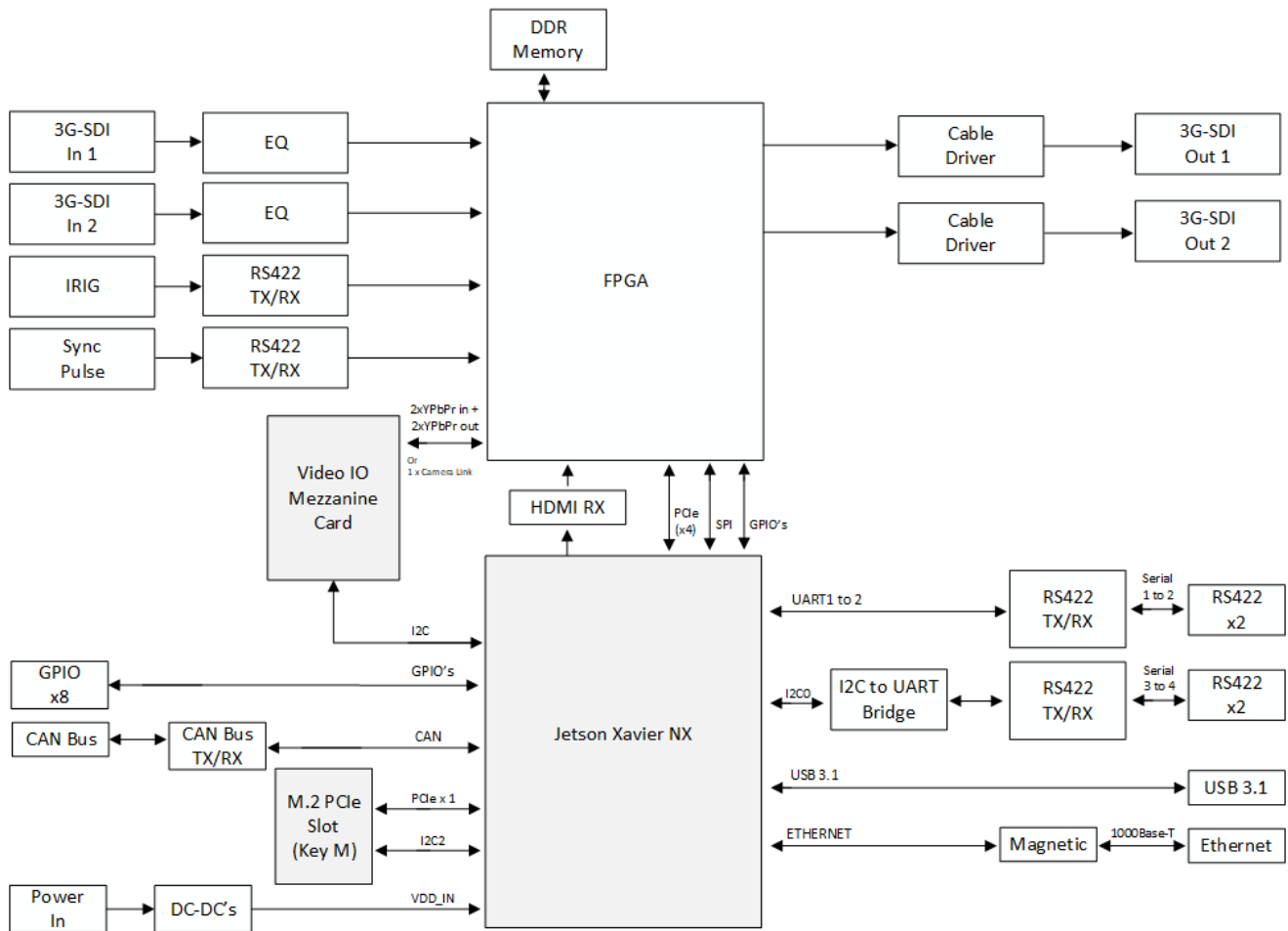

Video Interfaces

- 2 x digital video inputs – SD-SDI, HD-SDI, 3G-SDI, 480i60, 576i50, 720p50/59.94/60, 1080p25/29.97/30, 1080i50/59.94/60, 1080p50/59.94/60)
- 2 x 2-lane MIPI CSI video inputs
- Expansion options for Camera Link, CoaXPRESS, Analogue, and other video inputs with a mezzanine I/O card.

Video Outputs

- 2 x digital video outputs – SD-SDI, HD-SDI, 3G-SDI, 480i60, 576i50, 720p50/59.94/60, 1080p25/29.97/30, 1080i50/59.94/60, 1080p50/59.94/60, Selectable symbology overlay on outputs – Mezzanine card can also support video outputs.

Data Interfaces

- 1 x USB 3.0
- 1 x Ethernet – 10/100/1000 Base-T
- 4 x Serial RS422
- 1 x CAN bus
- 1 x IRIG DCLS input
- 8 x GPIO (4 inputs, 4 outputs)

Power

- 12VDC +/-5%
- <30W

Expansion

- 1 x M.2 slot (Key M)

Mechanical

- Dimensions 100 x 100 x 20mm (3.94" x 3.94" x 0.8")

Environmental

- Temperature – Operating -25C to +71C – Non-operating -40C to +85C
- Humidity – 5% to 95% non-condensing – Optional conformal coating available
- Shock – 30g, 11ms