

Modular Video Management Software



GRIP-VMS Graphical User Interface

Key Processing Options

DART: Software Video Tracking

- Multiple object moving target detection and tracking.
- Highly robust single target tracking modes for edge, centroid, and correlation tracking.

Panoramic Display

- High resolution 360° or sector persistent situational awareness from panning sensors or multiple TV/IR cameras.
- Real-time stitching with blended overlap regions performed on live video feeds.
- Multiple object detection when integrated with DART.

Digital Video Recording (DVR)

- Recording and playback of multiple video channels.
- SD & HD video supported
- Parallel recording of sensor metadata

Video Streaming

- Customized SD/HD video and metadata streams
- Standards include DVI over Ethernet, Def Stan 00-82 and Stanag 4609.

Electronic Image Stabilization (eStab)

- Compensates for sensor and platform movements using a combination of image processing algorithms and data from roll sensor inputs.

Image Enhancement

- Pixel level fusion of multiple video streams, including GPU accelerated rescaling and alignment algorithms.
- Contrast enhancement by high pass filtering and local contrast stretching.

Remote Designation

- Integration with GPS and data sources such as radar and AIS for target designation.

Designed and Manufactured in the UK

Electro-Optical System Control

GRIP-VMS is a comprehensive video management software tool enabling the complete control of electro-optical (EO) systems. A GRIP-VMS application is comprised of a number of standard software modules that can be custom configured to meet end user requirements. This modular approach enables the rapid and cost-effective deployment of sophisticated video management solutions with customers only needing to purchase those modules required for their particular-application.

The user interface and control methodology is designed to minimize the operator involvement whilst maximizing the quality of the information available. The software's Graphical User Interface can display multiple video streams in a flexible layout that can be customized to meet operational requirements. The display features on-screen presentation of ancillary data and semi-transparent video overlays for important user interface items. An operator can interact with GRIP-VMS and hence the EO system using a combination of touchscreen, joystick and keyboard control. It is also possible to remote control GRIP-VMS over an IP network.

GRIP-VMS provides the operator with control and feedback of all aspects of the EO system, including:

- Platform, position, velocity and operation mode
- Camera zoom, focus, offset and gain
- Other EO system elements (optional), such as Laser Range Finders, Burst Illumination Lasers, Inertial Measurement Units, etc.

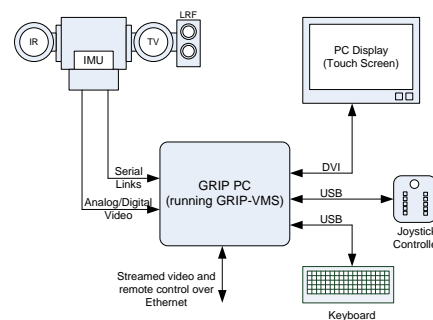

Example System Architecture

GRIP Hardware

GRIP-VMS has been designed to make use of the full capabilities of our ruggedized GRIP Computers, including the performance gains enabled by GPGPU processing, and allow seamless integration with GRIP DVR. This combination of hardware and software provides a complete rugged EO video management system suitable for deployment on a variety of manned and unmanned air, sea and land platforms.

